

ROBOTICS

Application manual

DeviceNet Master/Slave



Trace back information:
Workspace 24C version a9
Checked in 2024-09-26
Skribenta version 5.5.019

Application manual
DeviceNet Master/Slave

RobotWare 7.16

Document ID: 3HAC066562-001

Revision: F

The information in this manual is subject to change without notice and should not be construed as a commitment by ABB. ABB assumes no responsibility for any errors that may appear in this manual.

Except as may be expressly stated anywhere in this manual, nothing herein shall be construed as any kind of guarantee or warranty by ABB for losses, damage to persons or property, fitness for a specific purpose or the like.

In no event shall ABB be liable for incidental or consequential damages arising from use of this manual and products described herein.

This manual and parts thereof must not be reproduced or copied without ABB's written permission.

Keep for future reference.

Additional copies of this manual may be obtained from ABB.

Original instructions.

© Copyright 2019-2024 ABB. All rights reserved.
Specifications subject to change without notice.

Table of contents

Overview of this manual	7
Product documentation	9
Safety	11
Network security	12
Terminology	13
1 Introduction	15
1.1 What is DeviceNet?	15
1.2 DeviceNet for OmniCore	17
2 Hardware overview	19
2.1 Main computer and DeviceNet board	19
2.2 Cables and connections	22
2.2.1 Shield grounding and power	22
2.2.2 Termination resistors	24
2.2.3 Cabling	25
2.2.4 Selecting cables	26
2.2.5 Repeaters	27
2.3 Devices	29
3 Software overview	31
3.1 Information about the internal slave device	31
3.2 Information about the internal master	33
4 Configuring the internal slave device	35
4.1 Recommended working procedure	35
4.2 Configuring the internal slave device	36
4.3 Configuring the external master	39
5 Configuring the internal master	41
5.1 Recommended working procedure	41
5.2 Configuring the OmniCore controller	42
5.2.1 Manual configuration of I/O devices in RobotStudio	43
5.2.2 Manual configuration of I/O devices after a network scan	45
5.2.3 Automatic configuration of I/O devices	46
5.2.4 Configuration of third party devices	47
5.3 Communication between two OmniCore controllers	49
6 Boards and devices	51
6.1 General	51
6.1.1 DeviceNet network and I/O board status LED description	51
6.1.2 DeviceNet network status LEDs at power-up	53
6.1.3 External devices	54
6.1.4 Coil neutralization	55
6.1.5 Setting DeviceNet network ID	56
7 System parameters	59
7.1 Introduction	59
7.2 Type DeviceNet Network	61
7.2.1 The DeviceNet Network type	61
7.2.2 Name	62
7.2.3 Identification Label	63
7.2.4 Address	64
7.2.5 DeviceNet Communication Speed	65

Table of contents

7.2.6	Simulated	66
7.3	Type DeviceNet Device	67
7.3.1	Name	67
7.3.2	Connected to Industrial Network	68
7.3.3	State when System Startup	69
7.3.4	Trust Level	70
7.3.5	Simulated	71
7.3.6	Vendor Name	72
7.3.7	Product Name	73
7.3.8	Identification Label	74
7.3.9	Address	75
7.3.10	Vendor ID	76
7.3.11	Product Code	77
7.3.12	Device Type	78
7.3.13	Production Inhibit Time	79
7.3.14	Connection Type	80
7.3.15	Poll Rate	81
7.3.16	Connection Output Size	82
7.3.17	Connection Input Size	83
7.3.18	Quick Connect	84
7.4	Type DeviceNet Internal Device	85
7.4.1	Name	85
7.4.2	Connected to Industrial Network	86
7.4.3	Vendor Name	87
7.4.4	Product Name	88
7.4.5	Identification Label	89
7.4.6	Connection Input Size	90
7.4.7	Connection Output Size	91
7.4.8	Connection Type	92
7.4.9	Poll Rate	93
7.5	Type DeviceNet Command	94
7.5.1	Name	94
7.5.2	Device	95
7.5.3	Download Order	96
7.5.4	Value	97
7.5.5	Path	98
7.5.6	Service	100
8	Troubleshooting	101
8.1	Bus off	101
8.2	Bus Scan	102
Index		103

Overview of this manual

About this manual

This manual describes the option *3029-1 DeviceNet Single ch.* and contains instructions for the configuration. It also describes the configuration of boards and devices.

Usage

This manual should be used during installation and configuration of the DeviceNet network and upgrading of the option *3029-1 DeviceNet Single ch.*

Who should read this manual?

This manual is intended for:

- Personnel that are responsible for installations and configurations of industrial network hardware/software
- Personnel that make the configurations of the I/O system
- System integrators

Prerequisites

The reader should have the required knowledge of:

- Mechanical installation work
- Electrical installation work
- System parameter configuration

References

Document references

References	Document ID
<i>Application manual - Controller software OmniCore</i>	3HAC066554-001
<i>Operating manual - OmniCore</i>	3HAC065036-001
<i>Operating manual - RobotStudio</i>	3HAC032104-001
<i>Product manual - OmniCore C30</i>	3HAC060860-001
<i>Product manual - OmniCore C90XT</i>	3HAC073706-001
<i>Product manual - OmniCore V250XT Type B</i>	3HAC087112-001
<i>Product manual - OmniCore V400XT</i>	3HAC081697-001
<i>Product manual - OmniCore E10</i>	3HAC079399-001
<i>Technical reference manual - System parameters</i>	3HAC065041-001
<i>Technical reference manual - RAPID Instructions, Functions and Data types</i>	3HAC065038-001

Other references

References	Description
www.odva.org	The web site of ODVA (Open DeviceNet Vendor Association).

Continues on next page

Overview of this manual

Continued

References	Description
ODVA DeviceNet Specification, revision 2.0	Specification from ODVA (Open DeviceNet Vendor Associations).

Revisions

Revision	Description
A	Released with RobotWare 7.0.
B	Released with RobotWare 7.0.1. <ul style="list-style-type: none">• Cfg name removed from entire manual.
C	Released with RobotWare 7.6. <ul style="list-style-type: none">• Section Device descriptions removed.• Minor corrections in sections References on page 7, DeviceNet for OmniCore on page 17, Main computer and DeviceNet board on page 19, Devices on page 29 and External devices on page 54.
D	Released with RobotWare 7.7. <ul style="list-style-type: none">• Minor corrections in DeviceNet for OmniCore on page 17.
E	Released with RobotWare 7.13. <ul style="list-style-type: none">• Information about main computer DSQC1095 added in Main computer and DeviceNet board on page 19.
F	Released with RobotWare 7.16. <ul style="list-style-type: none">• Minor corrections.

Product documentation

Categories for user documentation from ABB Robotics

The user documentation from ABB Robotics is divided into a number of categories. This listing is based on the type of information in the documents, regardless of whether the products are standard or optional.



Tip

All documents can be found via myABB Business Portal, www.abb.com/myABB.

Product manuals

Manipulators, controllers, DressPack, and most other hardware is delivered with a **Product manual** that generally contains:

- Safety information.
- Installation and commissioning (descriptions of mechanical installation or electrical connections).
- Maintenance (descriptions of all required preventive maintenance procedures including intervals and expected life time of parts).
- Repair (descriptions of all recommended repair procedures including spare parts).
- Calibration.
- Troubleshooting.
- Decommissioning.
- Reference information (safety standards, unit conversions, screw joints, lists of tools).
- Spare parts list with corresponding figures (or references to separate spare parts lists).
- References to circuit diagrams.

Technical reference manuals

The technical reference manuals describe reference information for robotics products, for example lubrication, the RAPID language, and system parameters.

Application manuals

Specific applications (for example software or hardware options) are described in **Application manuals**. An application manual can describe one or several applications.

An application manual generally contains information about:

- The purpose of the application (what it does and when it is useful).
- What is included (for example cables, I/O boards, RAPID instructions, system parameters, software).
- How to install included or required hardware.
- How to use the application.

Continues on next page

- Examples of how to use the application.

Operating manuals

The operating manuals describe hands-on handling of the products. The manuals are aimed at those having first-hand operational contact with the product, that is production cell operators, programmers, and troubleshooters.

Safety

Safety regulations

Before beginning mechanical and/or electrical installations, ensure you are familiar with the safety information in the product manuals for the robot.

The integrator of the robot system is responsible for the safety of the robot system.

Network security

Network security

This product is designed to be connected to and to communicate information and data via a network interface. It is your sole responsibility to provide, and continuously ensure, a secure connection between the product and to your network or any other network (as the case may be).

You shall establish and maintain any appropriate measures (such as, but not limited to, the installation of firewalls, application of authentication measures, encryption of data, installation of anti-virus programs, etc) to protect the product, the network, its system and the interface against any kind of security breaches, unauthorized access, interference, intrusion, leakage and/or theft of data or information. ABB Ltd and its entities are not liable for damage and/or loss related to such security breaches, any unauthorized access, interference, intrusion, leakage and/or theft of data or information.

Terminology

Terms

Term	Explanation
Slave	I/O device that is controlled by a master in a DeviceNet network.
Internal Slave Device	A built-in device in the robot controller.
CIP	Common Industrial Protocol. Protocol that DeviceNet and EtherNet/IP are based on.
Client	See term <i>Master</i> . Some documents use the term <i>client</i> , whereas the ABB documentation use the term <i>Master</i> for DeviceNet network.
EDS	Electronic Data Sheet. EDS files contain the configuration details relevant to CIP devices.
Explicit Messages	An explicit message is a request or response oriented communication with other devices. These messages are mostly configuration data.
Master	Controls other devices (nodes) in a DeviceNet network.
ODVA	Open DeviceNet Vendor Association. Organization for networks built on CIP, for example DeviceNet and EtherNet/IP.
Server	See term <i>Slave</i> . Some documents use the term <i>server</i> , whereas the ABB documentation use the term <i>slave</i> for DeviceNet network.

This page is intentionally left blank

1 Introduction

1.1 What is DeviceNet?

General

DeviceNet is a communications link to connect industrial devices. It is a simple networking solution that reduces both cost and time to wire and install industrial automation devices, and the direct connectivity provides improved communication between devices. DeviceNet is an open network standard.

Here are some examples of applications:

- Peer-to-peer data exchange where a DeviceNet product can produce and consume messages
- Master/slave operation defined as a proper subset of Peer-to-Peer
- A DeviceNet product can function as a client or server, or both

DeviceNet specification

The DeviceNet specification defines a network communication system for moving data between elements of an industrial control system.

Communication protocol connections

The user must establish a connection with a device in order to exchange information with that device.

DeviceNet defines the following two different types of messaging:

Type of message	Description
Explicit messages	Explicit messages provide multi-purpose and point-to-point communication paths between two devices. Explicit messages provide the typical request/response oriented network communications used to perform node configuration and problem diagnosis.
I/O messages	I/O messages are for time-critical and control-oriented data, and they provide a dedicated and special-purpose communication path between a producing application and one or more consuming applications.

I/O messages - connection types

The following table describes the different types of I/O connections:

Type of I/O connection	Description
Polled connection	This technique is used for any amount of I/O data. Each slave receives a query from the master and may or may not respond before the next device has received a query. A slave can only respond to a request from the master.
Strobe connection	A single multicasting request. Quick exchange of a small amount of I/O data between a master and its slaves. The master sends one message that contains one bit of output data to each slave that has a strobe connection. This will result in a synchronized reading of data.

Continues on next page

1 Introduction

1.1 What is DeviceNet?

Continued

Type of I/O connection	Description
Change-Of-State (COS) connection	Devices are configured to produce data upon a change of I/O data. This technique can improve system throughput significantly. Data messages must be acknowledged by the receiver before new messages can be sent. Heart beat messages are used to tell the receiver that the device is still alive even if no data has changed state for a long time.
Cyclic connection	Devices are configured to produce data on a pre-configured time interval. Data production messages must be acknowledged before a new message can be sent.
Change-Of-State with acknowledge suppression	Devices are configured to produce data upon a change of application data. This technique can improve system throughput significantly. No acknowledge is required - that is, the receiver of data must be able to consume the data at the same rate as it is produced by the sending device.
Cyclic with acknowledge suppression	Devices are configured to produce data on a pre-configured time interval. No acknowledge is required - that is, the receiver of data must be able to consume the data at the same rate as it is produced by the sending device.

1.2 DeviceNet for OmniCore

General

The DeviceNet network for OmniCore is running on a single channel PCI Express board in the OmniCore main computer.

Options

With option *3029-1 DeviceNet Single channel*, the OmniCore controller can act as a master, slave, or both on the DeviceNet network.



Note

Note that the network settings are shared between the slave and the master if the OmniCore controller acts as both on the DeviceNet network.

Specification overview

Item	Specification
Industrial Network type	DeviceNet
Specification revision	DeviceNet specification release 2.0
Data rate	125, 250, 500 Kbps
Support for predefined Master/Slave connection set	Group 2 Client (Master) Group 2 Only Client (Master) Group 2 Server (Internal device)

This page is intentionally left blank

2 Hardware overview

2.1 Main computer and DeviceNet board

Main computer DSQC1025

Connections

The I/O network is connected to the DeviceNet board, DSQC1006, on the main computer. The DeviceNet board is a single channel board that can act both as a master and a slave simultaneously on the DeviceNet network.

The following figure illustrates the location of the DeviceNet board in the DSQC1025 main computer unit.

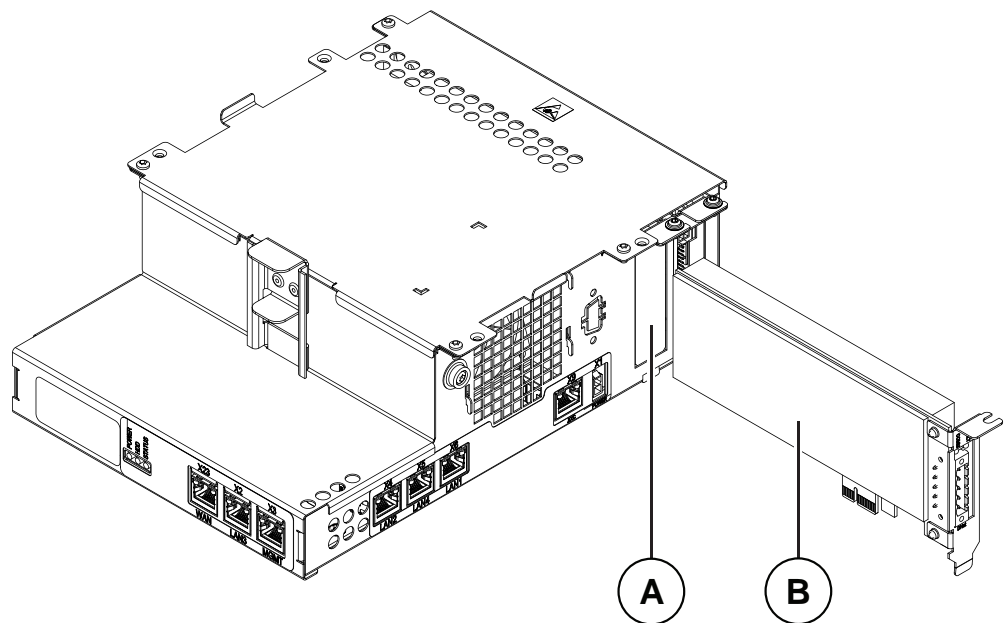

xx210000501

A	Slot for fieldbus, PCI express card
B	DeviceNet board

Available boards

The following master boards are available.

Description	Article number	Type designation
DeviceNet Board	3HAC043383-001	DSQC1006

Continues on next page

2 Hardware overview

2.1 Main computer and DeviceNet board

Continued

Main computer DSQC1095

Connections

The I/O network is connected to the DeviceNet M/S board, DSQC1096, on the main computer. The DeviceNet board is a single channel board that can act both as a master and a slave simultaneously on the DeviceNet network.

The following figure illustrates the location of the DeviceNet board in the main computer unit.

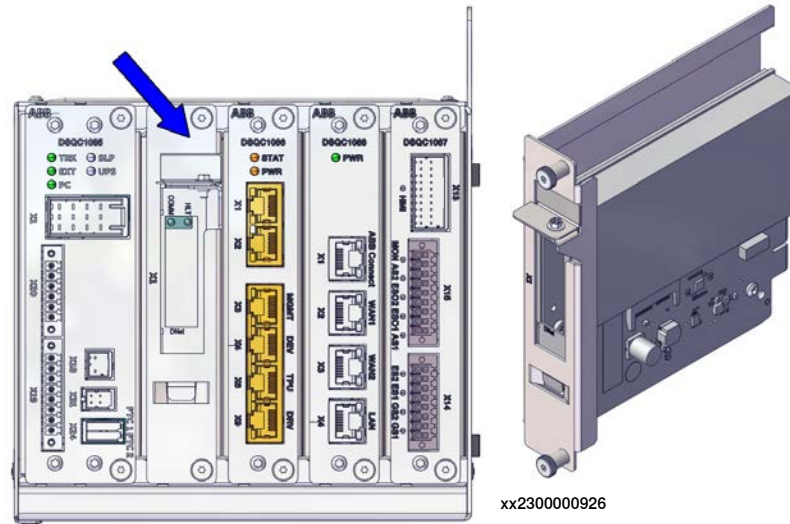

xx2300001738

xx2300000926

Available boards

The following master boards are available.

Description	Article number	Type designation
DeviceNet M/S	3HAC085254-001	DSQC1096

Installation of DeviceNet board

For information on how to install and replace the DeviceNet board, see the respective Product Manual for the controller.

The DeviceNet connector

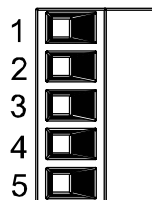

xx0200000292

The following table shows the connections to the DeviceNet connector:

I/O pin	Signal name	Wire color	Function
1	V-	black	DeviceNet network negative power (0 V)

Continues on next page

I/O pin	Signal name	Wire color	Function
2	CANL	blue	DeviceNet communication network terminal (low)
3	Shield	bare	Network cable shield
4	CANH	white	DeviceNet communication network terminal (high)
5	V+	red	DeviceNet network positive power (24 V DC)

LEDs on the DeviceNet board

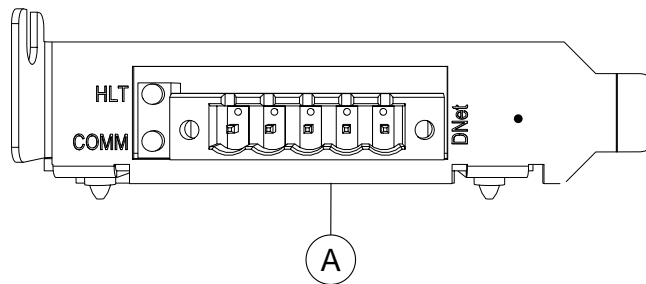

xx130000697

Designation	Color status	Description
COMM	Off	Offline - that is, board is not communicating on the network.
COMM	Flashing green	Online - that is, board is communicating on the network but no configured devices are found.
COMM	Solid green	Online and configured - that is, board is communicating on the network and at least one configured device is found.
COMM	Solid red	Bus off - that is, board unable to communicate on network.
HLT	Off	No power supply to PCI network.
HLT	Solid green	Board is running. Start-up self test OK.
HLT	Solid red	Board is not running, an error occurred during board firmware load or a fatal runtime error occurred.
		 Note This LED should be lit red at start-up until the proper software is loaded.

2 Hardware overview

2.2.1 Shield grounding and power

2.2 Cables and connections

2.2.1 Shield grounding and power

General

The DeviceNet shield and V- should be interconnected and grounded at only one place in the DeviceNet network. For more advanced connections with several power supplies refer to the *DeviceNet Specification*, see [References on page 7](#).

Power supply

The DeviceNet network needs to be powered by a separate power supply. The power supply can be located either inside or outside of the Omnicore controller. Some I/O devices may also require separate power supply for the I/O signals.

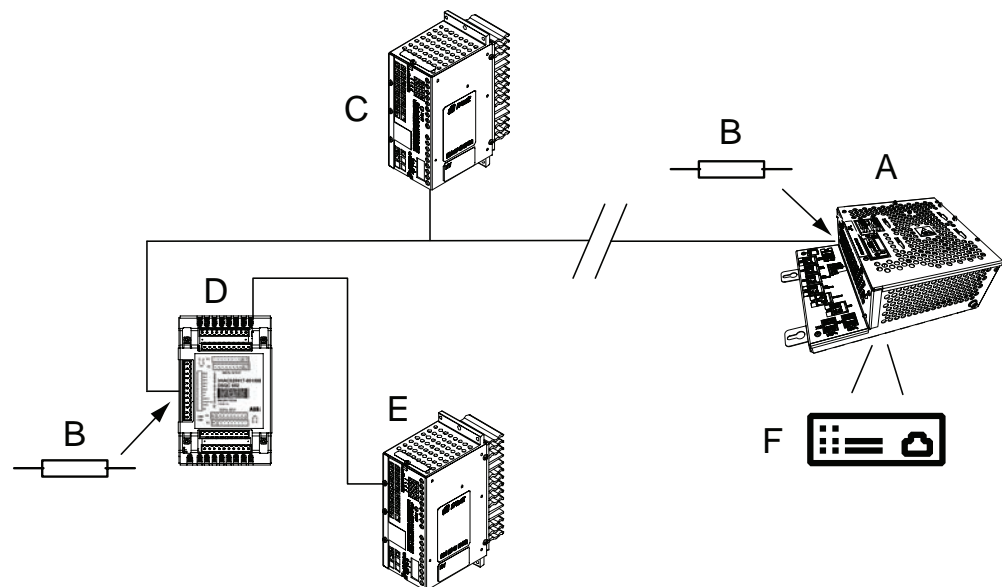

xx190000823

A	DeviceNet master/slave board, placed in the computer module.
B	Terminating resistors (121 Ohm).
C	24 VDC power supply, for the network.
D	Distributed digital I/O device.
E	24 VDC power supply, for the I/O signals of the device.
F	OmniCore controller.

Continues on next page

Grounding

The following illustration shows an example of cable grounding:

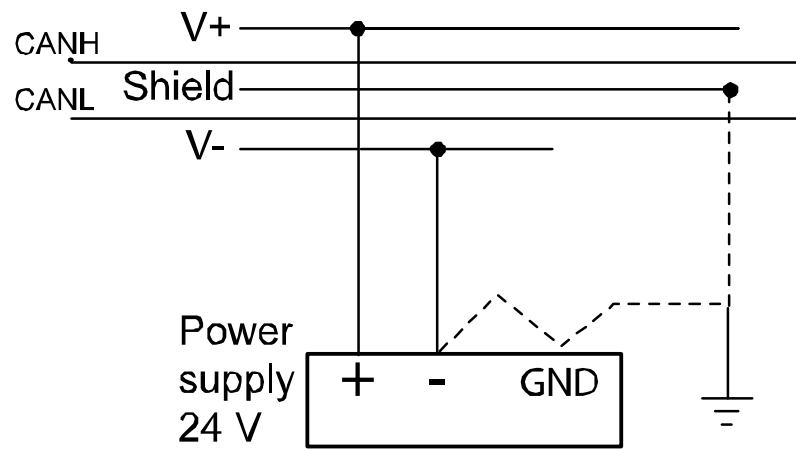

xx030000525

2 Hardware overview

2.2.2 Termination resistors

2.2.2 Termination resistors

General

Each end of the DeviceNet network must be terminated with a 121 ohm resistor. The two terminating resistors should be as far apart as possible.

The technical specification of the termination resistor is:

- 121 ohm, 1 %, 0.25 W metal film resistor

The termination resistor is placed in the cable connector. There is no internal termination on the DeviceNet PCI Express board.

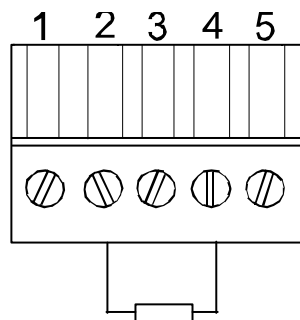

xx0400000674

Illustration

The illustration below shows an example of how to terminate the DeviceNet network.

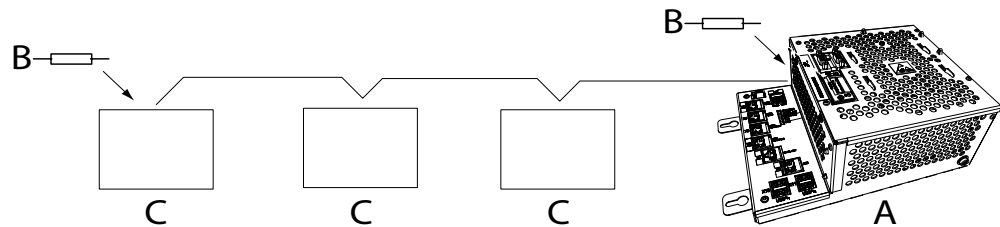

xx1300000698

A	DeviceNet PCI Express board.
B	Termination resistor
C	I/O device

2.2.3 Cabling

Physical connection between DeviceNet network and DeviceNet device

The following figure shows how the next DeviceNet node is connected to the DeviceNet network:

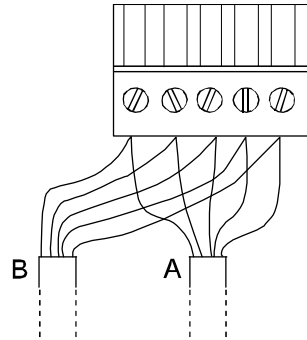

xx0400000849

A	Incoming DeviceNet network cable
B	Outgoing DeviceNet network cable

Illustration of trunk line and drop lines

The following figure illustrates a trunk line with drop lines. Thick or thin cable can be used for trunk lines and drop lines. For information about cable thickness and data rate, see the tables in the section [Selecting cables on page 26](#).

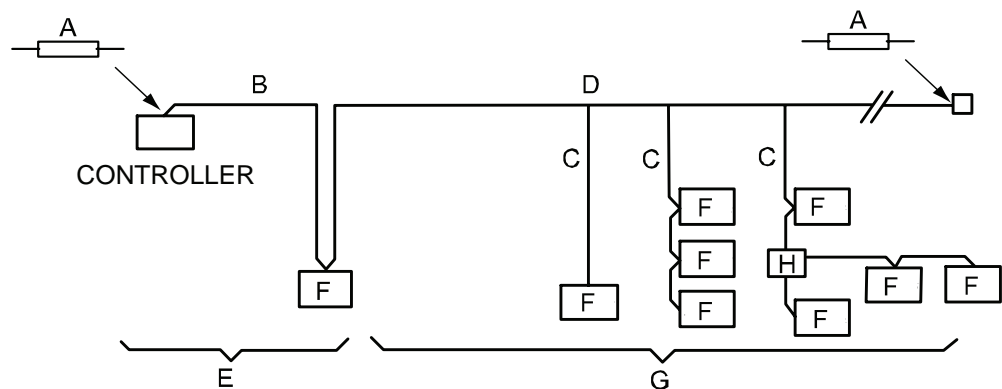

xx0300000579

A	Terminator
B	Trunk line
C	Drop line
D	Tap
E	Zero drop
F	Node
G	Short drop
H	T-connector

2 Hardware overview

2.2.4 Selecting cables

2.2.4 Selecting cables

DeviceNet network

The end-to-end network distance varies with data rate and cable thickness. For information about cable length dependency on cable type and data rate, see the following tables. For specification of the designations on the different cable types, see *ODVA DeviceNet Specification*.

Data rate 500 kbit/s

Cable type	Max. length
Thick trunk length	100 m (328 ft)
Thin trunk length	100 m (328 ft)
Flat trunk cable	75 m (246 ft)
Maximum drop length	6 m (20 ft)
Cumulative drop length	39 m (128 ft)

Data rate 250 kbit/s

Cable type	Max. length
Thick trunk length	250 m (820 ft)
Thin trunk length	100 m (328 ft)
Flat trunk cable	200 m (656 ft)
Maximum drop length	6 m (20 ft)
Cumulative drop length	78 m (256 ft)

Data rate 125 kbit/s

Cable type	Max. length
Thick trunk length	500 m (1,640 ft)
Thin trunk length	100 m (328 ft)
Flat trunk cable	380 m (1,250 ft)
Maximum drop length	6 m (20 ft)
Cumulative drop length	156 m (512 ft)

2.2.5 Repeaters

Usage

Repeaters are used for the following purposes:

- To avoid disturbances such as ESD/EFT, which may otherwise propagate to other parts of the network.
- To isolate noisy segments.
- When using several power supplies a repeater could be used to isolate the supplies from each other to avoid voltage potential differences and ground currents.

Extending the length of a trunk line

The following figure illustrates an application example where a repeater is used for extending the length of a trunk line:

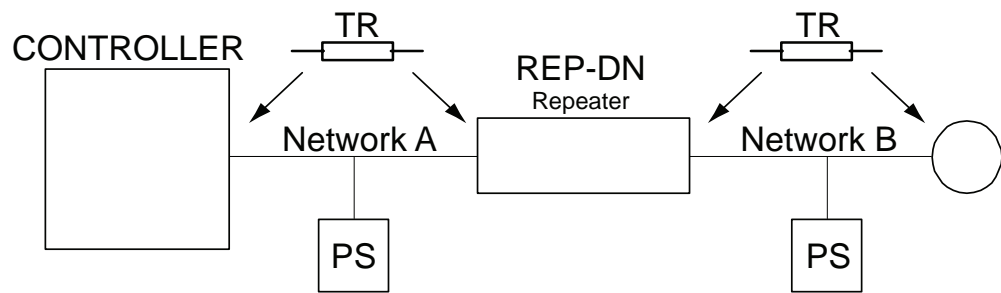

en040000724

Control	Controller
TR	Terminating resistor
PS	Power supply

Continues on next page

2 Hardware overview

2.2.5 Repeaters

Continued

Extending the length of a drop line

The following figure illustrates an application example where a repeater is used for extending the length of a drop line:

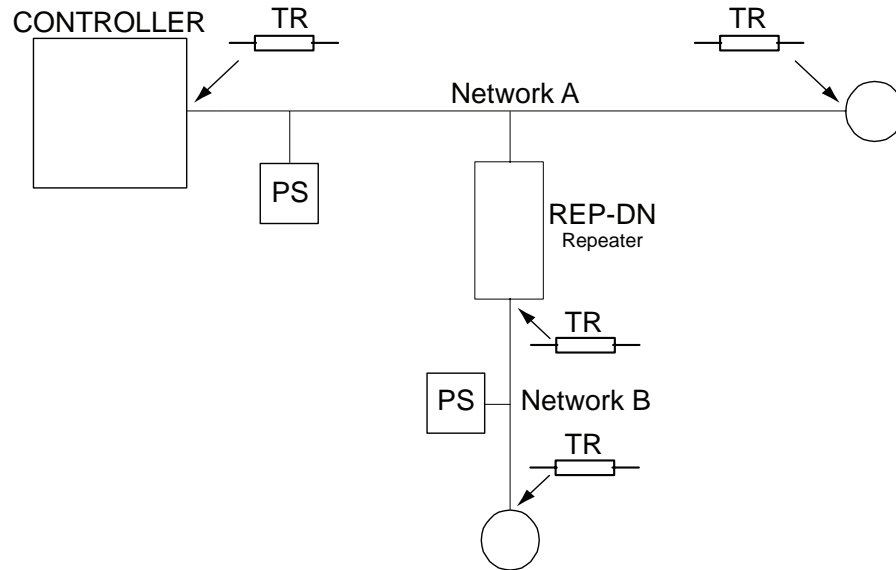

en040000725

Control	Controller
TR	Terminating resistor
PS	Power supply

2.3 Devices

General

It is possible to connect any type of DeviceNet compliant device on the DeviceNet master network. All devices should comply with the DeviceNet standard and be conformance tested by ODVA.

Devices may be mounted inside the controller.

For details about devices, see [Boards and devices on page 51](#).

Further information

The table gives references to additional information:

Information	See
How to install the devices and gateways mechanically and electrically.	See the respective Product Manual for the controller.
Allowed configurations of devices and how to setup the configurations.	<i>Technical reference manual - System parameters</i>

This page is intentionally left blank

3 Software overview

3.1 Information about the internal slave device

General

To use the DeviceNet internal slave device, the OmniCore controller must be installed with the option *3029-1 DeviceNet Single ch.*

The DeviceNet internal slave device can be used to:

- connect the OmniCore controller to a PLC.
- connect the OmniCore controller to another OmniCore controller which acts as a master.

The DeviceNet internal slave device shares address and physical connector with the master.

Predefined Network

When the robot system is installed with the DeviceNet option, a predefined industrial network with the name *DeviceNet* is created at system startup.

Predefined internal slave device

When the robot system is installed with the *3029-1 DeviceNet Single channel* option, a predefined internal slave device with the name *DN_Internal_Device* is created at system startup.

EDS file

An Electronic Data Sheet file, EDS file, is available for the internal slave device, matching the configuration of the predefined internal slave device.

The EDS file, *OmniCore_Slave_DSQC1006.eds*, for the internal slave device can be obtained from the RobotStudio or the OmniCore controller.

- **In the RobotWare installation folder in RobotStudio:**

...*RobotStudio*\Installation

Packages\ABB.RobotWare-x.x.x-xxx*Products*\RobotControl_x.x.xxx*utility*\service\EDS

- **On the OmniCore Controller:**

...*products*\RobotControl_x.x.x-xxx*utility*\service\EDS\

Changing the predefined input and output sizes

If another input or output size than the predefined is used, it is recommended to edit the values in the EDS file to match the new system parameter values.

An example from the EDS file where the predefined input and output sizes are changed from 8 bytes to 16 bytes is shown below:

```
[IO_Info]
Default = 0x0001;
Input1 = 16;
Output1 = 16;
```

Continues on next page

3 Software overview

3.1 Information about the internal slave device

Continued

I/O connection

The internal slave device supports both Polled and Change-of-State (COS) connection. Size and connection type supported are defined in parameter DeviceNet Internal Device, see [Type DeviceNet Internal Device on page 85](#).



Note

When using *Change-Of-State (COS)* on a DeviceNet device, the output signals of the device will be updated directly.



Note

If the DeviceNet internal slave device loses connection with the master, for example if the connection is interrupted, the input signals of the slave device are cleared (reset to zero).

Limitations

The DeviceNet internal slave device has the following limitations:

- The predefined internal slave device *DN_Internal_Device* is supporting a polled connection with the size of 8 digital input bytes and 8 digital output bytes but can be increased to the maximum value, which is 64 digital input bytes and 64 digital output bytes.
- If the *DN_Internal_Device* size is 8 DI and 8 DO bytes, input and output map starts at bit 0 and ends at bit 63.

3.2 Information about the internal master

General

To use the DeviceNet internal master, the OmniCore controller must be installed with the option *3029-1 DeviceNet Single channel*.

The DeviceNet internal master can be used to:

- connect DeviceNet I/O devices to the OmniCore controller.
- connect the OmniCore controller to another OmniCore controller which acts as a slave.

Predefined Network

When the robot system is installed with the *3029-1 DeviceNet Single channel* option, a predefined industrial network with the name *DeviceNet* is created at system startup.

Device Templates

There is a set of predefined device templates available for the internal master. These device templates can be used when defining a new device by using the Configuration Editor in RobotStudio or FlexPendant, see [Internal master configuration on page 42](#). Examples of present device templates are:

- *ABB DeviceNet Slave Device* is used on the master side to connect to an OmniCore DeviceNet slave using the DeviceNet PCI Express board.
- *DeviceNet Generic Device* is used on the master side to connect to an I/O device when the EDS file is unavailable, using *Change Of State* connection.

Generic Device template

Use the DeviceNet Generic Device template if the EDS file is unavailable. Using this template, you only need to know the network address of the I/O device to be able to communicate with it.

When the I/O device is connected, event messages containing the information necessary to configure the device, will appear on the Event Log window of the FlexPendant. The following information appears:

- Device identification system parameters (*Vendor ID*, *Device Type* and *Product Code*)
- The connection system parameters of the device (*Connection Type*, *Connection Input Size* and *Connection Output Size*)

Other system parameters for the device can be left to their default values.

Continues on next page

3 Software overview

3.2 Information about the internal master

Continued

For more information, see [Configuration of third party devices on page 47](#).



Note

The DeviceNet Generic Device template should only be used when installing and commissioning new I/O devices because it will increase the startup time. When restarting the system, the identification of the I/O device will be lost and there will not be any information if the I/O device is replaced with another I/O device, which has other functionality or size.

Template I/O configuration files

Template I/O configuration files are available for the DeviceNet I/O devices from *ABB Robotics*. These files contain a predefined I/O device with I/O signals for all available inputs and outputs. The files can be loaded to the controller, using RobotStudio or the FlexPendant, to facilitate and speed up the configuration.

The template configuration files can be obtained from the RobotStudio or the OmniCore controller.

- In the RobotWare installation folder in RobotStudio:

...\\RobotStudio\\Installation

Packages\\ABB.RobotWare-xxx-xxx\\Products\\RobotControl_xxxxx\\utility\\service\\ioconfig\\DeviceNet

- On the OmniCore Controller:

...\\products\\RobotControl_x.x.x-xxx\\utility\\service\\ioconfig\\DeviceNet

For more information about the DeviceNet devices from *ABB Robotics*, see [Boards and devices on page 51](#).

Number of allowed I/O devices

A maximum number of 40 user defined I/O devices can be configured on the DeviceNet industrial network in the OmniCore system, however it is recommended only 20 user defined I/O devices should be configured. For more information see *Device Type of I/O System* section in *Technical reference manual - System parameters*, see [References on page 7](#). DeviceNet has an addressing range from 0-63.

The following are counted as user defined I/O devices:

- All DeviceNet slave I/O devices connected to the OmniCore DeviceNet master.
- Simulated DeviceNet I/O devices.



Note

The internal slave device is not counted as a user defined I/O device.

ABB I/O devices and I/O devices from other vendors can be used. No additional software option, except for the *3029-1 DeviceNet Single channel* option, is required to run I/O devices from other vendors.

4 Configuring the internal slave device

4.1 Recommended working procedure

General

The internal slave device is pre-installed at the system startup. However, the Input and Output size, as well as the ConnectionType and the PollRate of the device can be changed.

This section describes the recommended working procedure when installing and configuring an internal slave device. The working procedure helps to understand the dependencies between the different steps.

When the OmniCore controller is connected to an external master, the OmniCore controller acts as an ordinary device on the DeviceNet network.



Note

It is only possible to have one internal slave device.

Basic steps

Use this procedure to install and configure a DeviceNet slave.

Action	See
Configure the internal slave device in the OmniCore controller using RobotStudio.	Configuring the internal slave device on page 36

4 Configuring the internal slave device

4.2 Configuring the internal slave device

4.2 Configuring the internal slave device

Internal slave configuration

Use this procedure to configure the internal slave device in the OmniCore controller, using RobotStudio.

- 1 Start RobotStudio and connect to the OmniCore controller. Request write access.
- 2 Open the **Configuration Editor** and select **I/O System**.
For more information about the parameters, see [System parameters on page 59](#).
- 3 In the **Type** list, click **DeviceNet Network**, right-click in the workspace on the DeviceNet item and select **Edit DeviceNet Network**.
- 4 The **Instance Editor** is displayed:

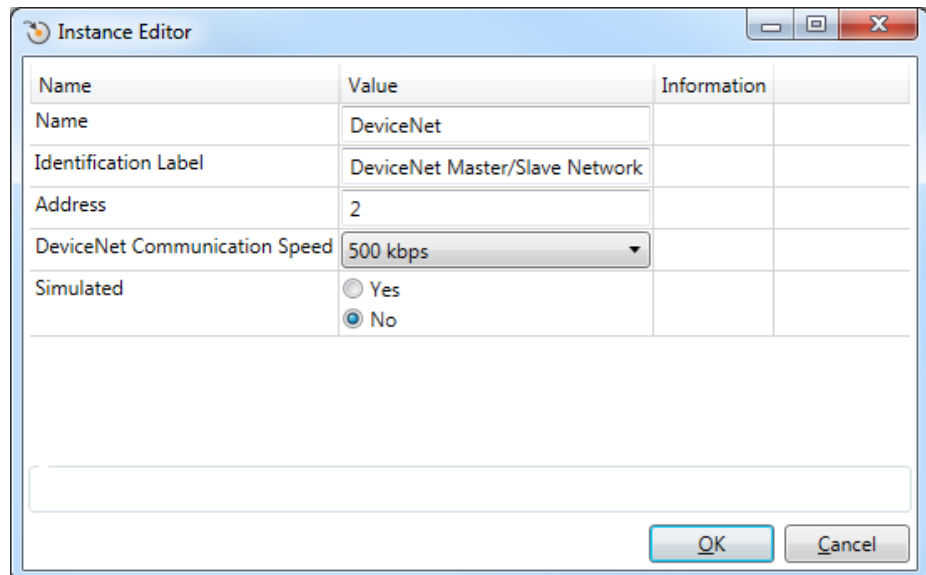

The screenshot shows the 'Instance Editor' dialog box with the following configuration:

Name	Value	Information
Name	DeviceNet	
Identification Label	DeviceNet Master/Slave Network	
Address	2	
DeviceNet Communication Speed	500 kbps	
Simulated	<input type="radio"/> Yes <input checked="" type="radio"/> No	

Buttons: OK, Cancel

xx1400001531

If needed, change the DeviceNet address on the OmniCore DeviceNet master and internal slave device.

- **Address**, set the address of the DeviceNet master and internal slave device.

Click **OK**.



Note

Note that the network settings are shared between the internal slave device and the internal master if the OmniCore controller acts as both on the DeviceNet network.

- 5 In the **Type** list, click **DeviceNet Internal Device**, right-click in the workspace on the DN_Internal_Device item and select **Edit DeviceNet Internal Device(s)**.

Continues on next page

4 Configuring the internal slave device

4.2 Configuring the internal slave device

Continued

- 6 In the **Instance Editor**, change the default values for **Connection Input Size**, **Connection Output Size**, **Connection Type** and **PollRate**.

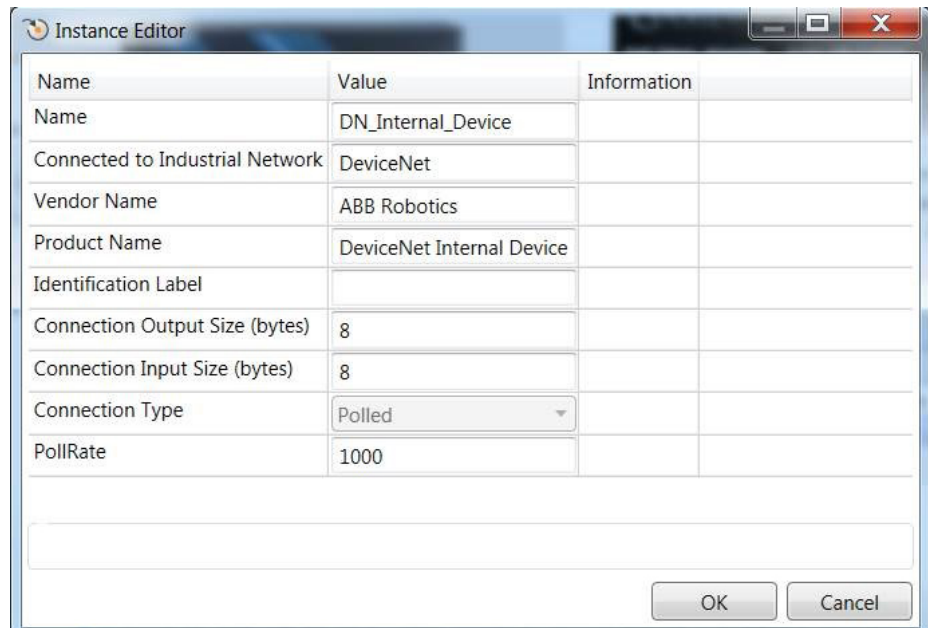

The screenshot shows the 'Instance Editor' dialog box with the following configuration:

Name	Value	Information
Name	DN_Internal_Device	
Connected to Industrial Network	DeviceNet	
Vendor Name	ABB Robotics	
Product Name	DeviceNet Internal Device	
Identification Label		
Connection Output Size (bytes)	8	
Connection Input Size (bytes)	8	
Connection Type	Polled	
PollRate	1000	

At the bottom right of the dialog box are 'OK' and 'Cancel' buttons.

xx1900001019

Click **OK**.

- 7 In the **Type** list, click **Signal**.

Continues on next page

4 Configuring the internal slave device

4.2 Configuring the internal slave device

Continued

Add I/O signals for the internal slave device, *DN_Internal_Device*.

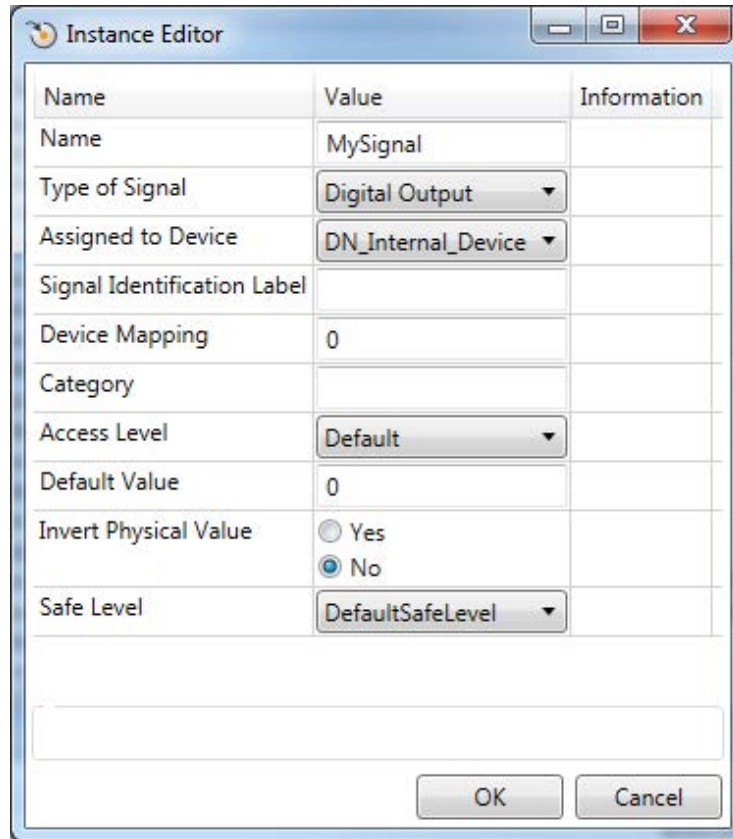

The screenshot shows the 'Instance Editor' dialog box with the following configuration:

Name	Value	Information
Name	MySignal	
Type of Signal	Digital Output	
Assigned to Device	DN_Internal_Device	
Signal Identification Label		
Device Mapping	0	
Category		
Access Level	Default	
Default Value	0	
Invert Physical Value	<input type="radio"/> Yes <input checked="" type="radio"/> No	
Safe Level	DefaultSafeLevel	

Buttons: OK, Cancel

xx1400001533

8 Restart the controller.

Now the OmniCore controller is ready to be contacted from another DeviceNet master.



Note

For the DeviceNet internal slave device, both the input and output map starts at bit 0 and ends at bit 63.

4.3 Configuring the external master

General

The external master is configured using the vendor specific configuration tool that is delivered, or bought, together with the master.

The tool is used in order to specify all the devices in the DeviceNet network. One of the devices is the internal slave device of the OmniCore controller. To be able to create such a device, the EDS file describing the internal slave device has to be imported into the vendor specific configuration tool, see [EDS file on page 31](#).

All other I/O devices used in the network also has to have its EDS file imported.

External master configuration

This procedure describes the general steps that needs to be performed when configuring an external master, independent of which tool is used.

- 1 Use the external master configuration tool to:
 - Specify the address of the external DeviceNet master.
 - Import the EDS files for the internal slave device and all other types of I/O devices in the network.
 - Add the OmniCore controller I/O device and set the same DeviceNet address as in the OmniCore controller.
 - Add any other I/O devices into the network structure.
 - Add signals for all I/O devices including the OmniCore controller I/O device.

This page is intentionally left blank

5 Configuring the internal master

5.1 Recommended working procedure

General

This section describes the recommended working procedure when installing and configuring a DeviceNet internal master. The working procedure helps to understand the dependencies between the different steps.

Basic steps

Use this procedure to install and configure a DeviceNet master.

	Action	See
1	Configure the master in the OmniCore controller using RobotStudio.	Configuring the OmniCore controller on page 42
2	Manual configuration of I/O devices in RobotStudio	Manual configuration of I/O devices in RobotStudio on page 43
3	Manual configuration of I/O devices after a network scan	Manual configuration of I/O devices after a network scan on page 45
4	Automatic configuration of I/O devices	Automatic configuration of I/O devices on page 46
5	Configuring third party devices.	Configuration of third party devices on page 47.

Additional configuration

Action	See
Setting up communication between two OmniCore controllers.	Communication between two OmniCore controllers on page 49

5 Configuring the internal master

5.2 Configuring the OmniCore controller

5.2 Configuring the OmniCore controller

Internal master configuration

Use this procedure to configure the master in the OmniCore controller, using the Configuration Editor in RobotStudio.

- 1 Start RobotStudio and connect to the OmniCore controller. Request write access.
- 2 Click **Configuration Editor** and select **I/O System**.
For more information about the parameters, see [System parameters on page 59](#).
- 3 In the **Type** list, click **Industrial Network** and then right-click in the workspace on the DeviceNet and select **Edit Industrial Network**.
- 4 If needed, change the parameter values for the network.

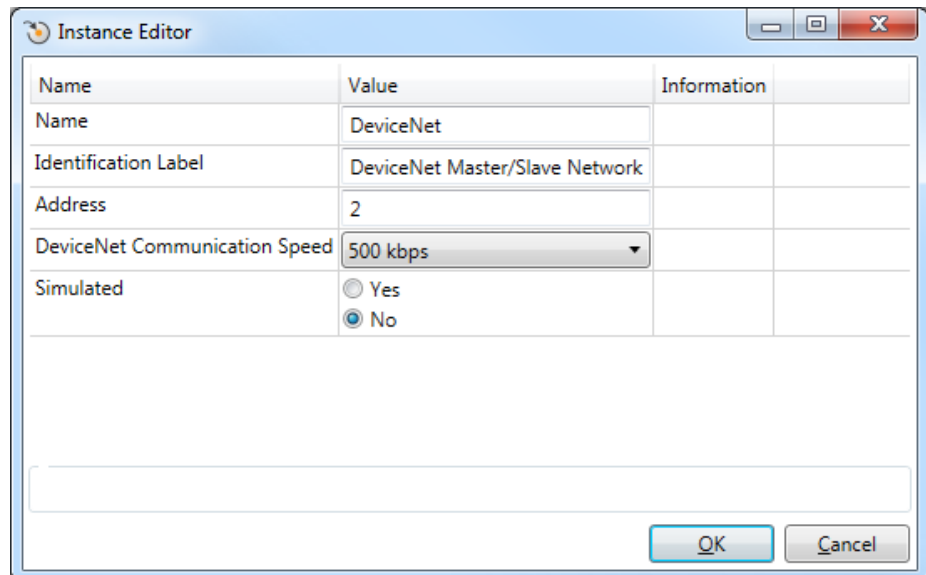

The screenshot shows the 'Instance Editor' dialog box with the following configuration:

Name	Value	Information
Name	DeviceNet	
Identification Label	DeviceNet Master/Slave Network	
Address	2	
DeviceNet Communication Speed	500 kbps	
Simulated	<input type="radio"/> Yes <input checked="" type="radio"/> No	

Buttons: OK, Cancel

xx1400001531

- **Address**, set the address of the DeviceNet master.

Click **OK**.



Note

Note that the network settings are shared between the internal slave device and the internal master if the OmniCore controller acts as both on the DeviceNet network.

- 5 Add I/O devices to the DeviceNet master.
See step 2 of [Manual configuration of I/O devices in RobotStudio on page 43](#).

Continues on next page

5.2.1 Manual configuration of I/O devices in RobotStudio

Procedure

Use this procedure to configure the I/O devices in RobotStudio.

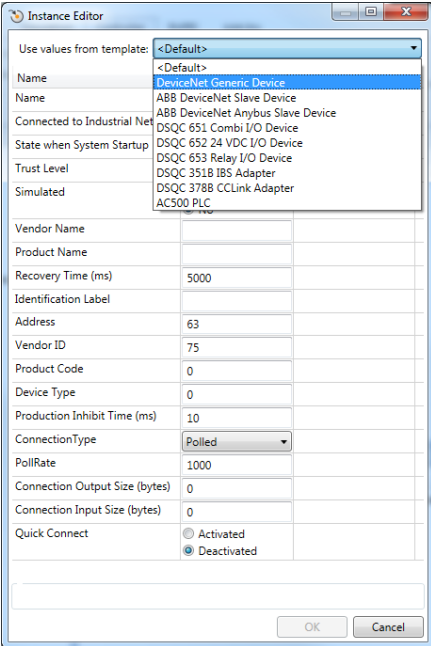
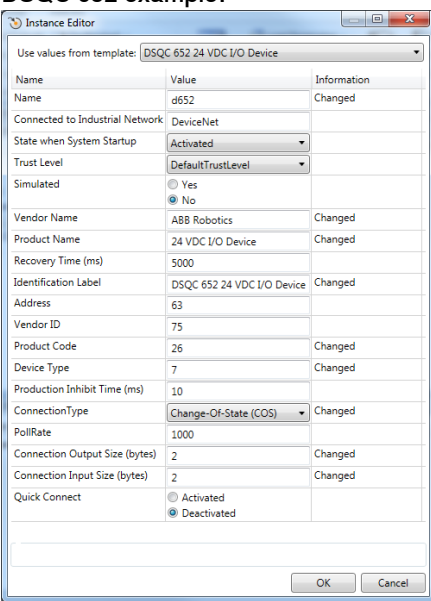
	Action	Note
1	Start RobotStudio and connect to the Omni-Core controller. Request write access.	
2	If required, change the address of the DeviceNet network.	See step 3 of <i>Internal master configuration on page 42</i> .
3	<p>In the Type list, click DeviceNet Device then right-click in the workspace and select New DeviceNet Device.</p> <ul style="list-style-type: none"> Select a predefined device template or enter the parameter values to configure the device. 	 <p>xx1500000938</p>
4	<p>Enter the parameter values for the device.</p> <ul style="list-style-type: none"> Name, user defined. Connected to Industrial Network, shall be <i>DeviceNet</i>. Address, the address of the device. Other parameters as well can be changed if applicable. <p>Click OK.</p>	<p>DSQC 652 example:</p>  <p>xx1500000939</p>

Continues on next page

5 Configuring the internal master

5.2.1 Manual configuration of I/O devices in RobotStudio

Continued

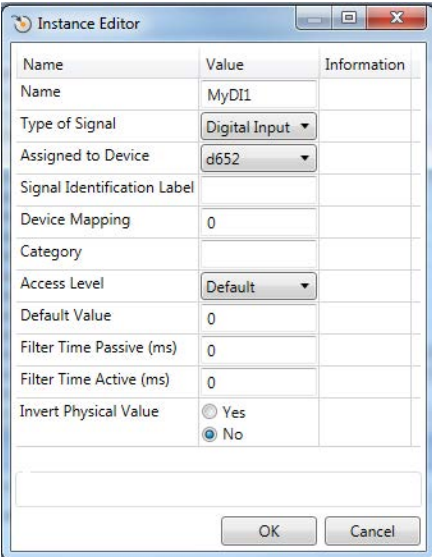
	Action	Note
5	In the type list, click Signal .	
6	Add I/O signals to the devices <ul style="list-style-type: none"> • Name, user defined. • Type of Signal, select signal type from the drop-down list. • Assigned to Device, select from the list of previously defined devices. • Device Mapping, specifies which bit the signal uses in the I/O memory of the I/O device. Click OK .	 <p>xx1400001543</p>
7	Restart the OmniCore controller.	

5.2.2 Manual configuration of I/O devices after a network scan

Procedure

Use this procedure to configure the I/O devices by using network scan.

	Action	Note
1	Start RobotStudio and connect to the OmniCore controller. Request write access. To proceed with the steps, system should be in manual mode.	
2	Connect the I/O devices physically to the DeviceNet network that needs to be configured.	
3	Change the address of the DeviceNet master, if necessary.	 Note See step 3 of Internal master configuration on page 42 .
4	Click I/O System to expand the folder. Select DeviceNet and right-click in the workspace and navigate the shortcut menu to select Scan network <ul style="list-style-type: none"> Information event messages are generated for the I/O device that is discovered on the network. 	
5	For each I/O device that the scan operation discovered, which should be configured in the OmniCore system.	See Manual configuration of I/O devices in RobotStudio on page 43 .



5 Configuring the internal master

5.2.3 Automatic configuration of I/O devices

5.2.3 Automatic configuration of I/O devices

Procedure

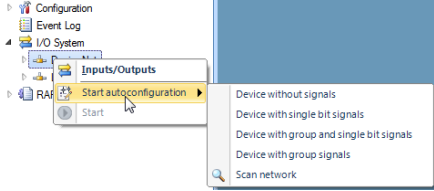
Use this procedure to configure the I/O devices by using Auto Configuration.

	Action	Note
1	<p>Start RobotStudio and connect to the OmniCore controller. Request write access.</p> <p>To proceed with the steps, system should be in manual mode.</p>	
2	<p>Connect the I/O devices physically to the DeviceNet network that needs to be configured.</p> <p> Note</p> <p>The I/O devices found on the network that are not configured in the OmniCore controller or occupied by another master will be configured. If the I/O device requires additional configuration through DeviceNet Command, this must be added manually.</p>	<p>See step 3 of Internal master configuration on page 42.</p>
3	<p>Click I/O System to expand the folder. Select DeviceNet and right-click in the workspace and point to Start autoconfiguration to select the required option.</p> <p>Auto configuration options are:</p> <ul style="list-style-type: none"> • <i>Device without signals</i> • <i>Device with single bit signals</i> • <i>Device with group and single bit signals</i> • <i>Device with group signals</i> 	 <p>xx1400002204</p> <p> Note</p> <p>By default the device is mapped to 8 bits signal, when option <i>Device with group signals</i> is selected for auto configuration. Refer <i>Technical reference manual - System parameters</i> for more information on limitations of size of I/O signals in device mapping.</p>
4	<p>Information event messages are generated for each new I/O device found and configured.</p>	
5	<p>If needed, change the parameters for the included I/O devices and remap or change the signals added on the I/O device to reflect the meaning of the data bits.</p>	<p>See step 4 of Manual configuration of I/O devices in RobotStudio on page 43.</p>

5.2.4 Configuration of third party devices

Description of DeviceNet generic device templates

The predefined device template *DeviceNet Generic Device* can be used to set up a communication with any I/O device in an easy way.

Usage

When new DeviceNet I/O devices should be configured and the information available is not sufficient to create a new device, then the template *DeviceNet Generic Device* could be used to retrieve necessary information. This could be the case when third party devices should be configured and the EDS file is missing.



Note

When using the template *DeviceNet Generic Device*, you accept any type of device as long as the address matches - that is, make sure to use the correct address.

Prerequisites

The network address of the I/O device must be known and the baud rate must match the master.

Data presented on the FlexPendant

In the Event Log window of the RobotStudio or FlexPendant, you get information about the following system parameters:

- *Vendor ID*
- *Product Code*
- *Device Type*
- *Connection Type*
- *Connection Input Size*
- *Connection Output Size*

How to use the DeviceNet Generic Device template

The following steps describe how to use the *DeviceNet Generic Device* template:

	Action	Note
1	Start RobotStudio and connect to the OmniCore controller. Request write access.	
2	Determine the address on the physical I/O device.	

Continues on next page

5 Configuring the internal master

5.2.4 Configuration of third party devices

Continued

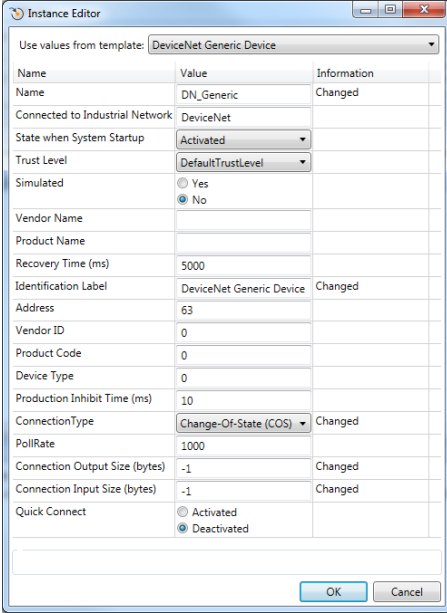
	Action	Note
3	Add new DeviceNet Device and select the DeviceNet Generic Device template from the Use values from template drop-down list.	<p>For information see <i>Operating manual - RobotStudio</i>.</p>  <p>The screenshot shows the 'Instance Editor' dialog box for a 'DeviceNet Generic Device'. It features a table with columns for 'Name', 'Value', and 'Information'. The 'Use values from template' dropdown is set to 'DeviceNet Generic Device'. The table lists various parameters such as Name (DN_Generic), Connected to Industrial Network (DeviceNet), State when System Startup (Activated), Trust Level (DefaultTrustLevel), Simulated (No), Vendor Name, Product Name, Recovery Time (ms) (5000), Identification Label (DeviceNet Generic Device), Address (63), Vendor ID (0), Product Code (0), Device Type (0), Production Inhibit Time (ms) (10), ConnectionType (Change-Of-State (COS)), PollRate (1000), Connection Output Size (bytes) (-1), Connection Input Size (bytes) (-1), and Quick Connect (Deactivated). The 'Information' column indicates which values have been changed. At the bottom, there are 'OK' and 'Cancel' buttons.</p> <p>xx1400002213</p>
4	Restart the system.	
5	View event log that shows device identification parameters and connection support information.	<p>For information see <i>Operating manual - RobotStudio</i> and/or <i>Operating manual - OmniCore</i>.</p> <p>Two event messages appear in the Event Log window in RobotStudio.</p>
6	Create a new I/O device by using information from the event log.	See Manual configuration of I/O devices in RobotStudio on page 43 .
7	Define the I/O signals.	See Manual configuration of I/O devices in RobotStudio on page 43 .
8	Restart the system.	

5.3 Communication between two OmniCore controllers

Usage

When two OmniCore controllers are connected to each other via DeviceNet, one of them must be configured as a master and the other one must be configured as a slave.

Limitations

The DeviceNet address cannot be the same on the two controllers since they shall be interconnected.



Note

At startup, both controllers will have the same default value for the DeviceNet address. One address needs to be changed.

Illustration

The figure illustrates DeviceNet communication between two OmniCore controllers.

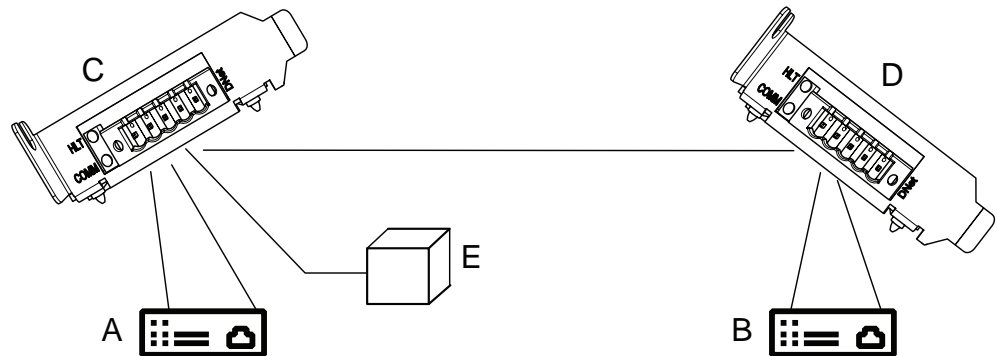

xx190000871

A	OmniCore DeviceNet master
B	OmniCore DeviceNet slave
C	DeviceNet PCI Express board, DSQC1006, configured as a master using the default address.
D	DeviceNet PCI Express board, DSQC1006, configured as a slave using a different address.
E	Power supply unit, 24 VDC

Configuring the master/slave controllers

The following procedures describe the configuration of a hardware setup like the one illustrated in the picture in section [Illustration on page 49](#).

- 1 Configure the OmniCore DeviceNet internal slave device in controller B according to the configuration procedure for the internal slave device. See [Configuring the internal slave device on page 36](#).
 - Change the DeviceNet address on the OmniCore DeviceNet slave device.

Continues on next page

5 Configuring the internal master

5.3 Communication between two OmniCore controllers

Continued

- Use the predefined internal slave device with the name *DN_Internal_Device*.



Note

The selected **ConnectionType** must match the corresponding value defined for the other controller.

- 2 Configure the OmniCore DeviceNet master in controller A to connect to the OmniCore DeviceNet internal slave device in controller B, according to the configuration procedure for the internal master. See [Configuring the OmniCore controller on page 42](#).
 - Use the default value for the DeviceNet address.
 - Use the DeviceNet device template *DN_Device* when adding the slave in the master controller.



Note

The selected **ConnectionType** must match the corresponding value defined for the other controller.

- 3 Configure signals on the created devices in both controllers.



Note

Input signals to the *DN_Internal_Device* in the slave controller, are configured as outputs from the device on the master controller, and vice versa.

- 4 Physically interconnect the two OmniCore controllers. See [Cables and connections on page 22](#).
- 5 Restart the slave controller.
- 6 Restart the master controller.

The master will now connect to the slave controller.
- 7 Now it is possible to set output signals on one controller.

The output signals appear as inputs on the other controller, and vice versa.

6 Boards and devices

6.1 General

6.1.1 DeviceNet network and I/O board status LED description

General

Each of the devices connected to the DeviceNet network includes LED indicators which indicate the condition of the device and the function of the network communication.

LEDs

The LEDs found on the devices connected may be divided into two categories.

Common LEDs

The following LEDs can be found on all devices:

- MS - Module status
- NS - Network status

Specific LEDs

Certain devices also include the following LEDs:

- DeviceNet Tx - DeviceNet network transmit
- DeviceNet Rx - DeviceNet network receive

MS - Module status

The bicolor (green/red) LED indicates the status of the device. It indicates whether or not the device has power and is operating properly. The LED is controlled by software. The following table shows the different states of the MS LED.

LED color	Description	Remedy/cause
OFF	No power applied to the device.	Check power supply.
GREEN steady	Device is operating in a normal condition.	If no light, check other LED modes.
GREEN flashing	Device needs commissioning due to missing, incomplete or incorrect configuration. The device may be in the stand-by state.	Check system parameters. Check messages.
RED flashing	Recoverable minor fault.	Check messages.
RED steady	The device has an unrecoverable fault.	Device may need replacing.
RED/GREEN flashing	The device is running self test.	If flashing for more than a few seconds, check hardware.

Continues on next page

6 Boards and devices

6.1.1 DeviceNet network and I/O board status LED description

Continued

NS - Network status

The bicolor (green/red) LED indicates the status of the communication link. The LED is controlled by software. The following table shows the different states of the NS LED.

LED color	Description	Remedy/cause
OFF	Device has no power or is not online. The device has not completed the Dup_MAC_ID test yet.	Check status of MS LED. Check power to affected module.
GREEN steady	The device is online and has connection in the established state. For a group 2 device only: the device is allocated to a master. For a UCMM capable device: the device has one or more established connections.	If no light, check other LED modes.
GREEN flashing	Device is online, but has no connections in the established state. The device has passed the Dup_MAC_ID test, is online, but has no established connections to other nodes. For a group 2 device only: the device is not allocated to a master. For a UCMM capable device: the device has no established connections.	Check that other nodes in the network are operative. Check parameter to see whether module has correct ID.
RED flashing	One or more I/O connections are in the time-out state.	Check system messages.
RED steady	Failed communication device. The device has detected an error rendering it incapable of communicating on the network. (Duplicate MAC_ID, or Bus-off).	Check system messages and parameters.

DeviceNet Tx - DeviceNet network transmit

The following table shows the different states of the DeviceNet Tx LED.

LED color	Description	Remedy/cause
GREEN steady	Physically connected to the DeviceNet Tx line.	If no light when transmission is expected, check error messages. Check system boards in rack.
GREEN flashing	Flashes when the device is transmitting data on the DeviceNet network.	

DeviceNet Rx - DeviceNet network receive

The following table shows the different states of the DeviceNet Rx LED.

LED color	Description	Remedy/cause
GREEN steady	Physically connected to the DeviceNet Rx line.	If no light, check network and connections.
GREEN flashing	Flashes when the device is receiving data on the DeviceNet network.	

6.1.2 DeviceNet network status LEDs at power-up

Process

The system performs a test of the MS and NS LEDs during startup. The purpose of this test is to check that all LEDs are working properly. The test runs as follows:

Order	LED action
1	NS LED is switched Off.
2	MS LED is switched On green for approx. 0.25 seconds.
3	MS LED is switched On red for approx. 0.25 seconds.
4	MS LED is switched On green.
5	NS LED is switched On green for approx. 0.25 seconds.
6	NS LED is switched On red for approx. 0.25 seconds.
7	NS LED is switched On green.

Additional LEDs

If a device has other LEDs, each LED is tested in sequence.

6 Boards and devices

6.1.3 External devices

6.1.3 External devices

General

Up to 40 I/O devices can be connected to the same controller.

Requirements

Description	Data/value	Further information
The maximum cable length between controller and external I/O device.	100 m	Selecting cables on page 26.
Controller placement on cable chain.	At one end or anywhere between the ends.	
Power supply to devices.	24 VDC	
Termination of DeviceNet network.	121 ohm resistor	Termination resistors on page 24.

6.1.4 Coil neutralization

External devices

External relay coils, solenoids, and other devices that are connected to the controller must be neutralized. The following sections describe how this can be done.



Note

The turn-off time for DC relays increases after neutralization, especially if a diode is connected across the coil. Varistors give shorter turn-off times. Neutralizing the coils lengthens the life of the switches that control them.

Clamping with a diode

The diode should be dimensioned for the same current as the relay coil, and a voltage of twice the supply voltage.

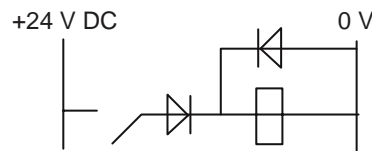

xx0100000163

Clamping with a varistor

The varistor should be dimensioned for the same current as the relay coil, and a voltage of twice the supply voltage.

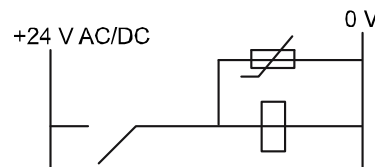

xx0100000164

Clamping with an RC circuit

R 100 ohm, 1W C 0.1 - 1 mF.

>500 V max. voltage, 125 V nominal voltage.

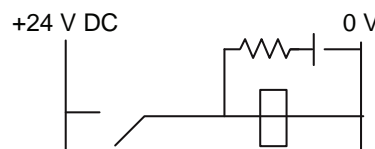

xx1900001024

6 Boards and devices

6.1.5 Setting DeviceNet network ID

6.1.5 Setting DeviceNet network ID

Description

Each device is given a unique address (ID).

How to set the ID

The connector contains address pins and can be keyed as shown in the following figure. When all terminals are unconnected the highest address 63 is obtained. When all terminals are connected to 0 V, the address would be 0.

To obtain the address 10:	Cut address pins 2 and 8
To obtain the address 25:	Cut address pins 1, 8 and 16

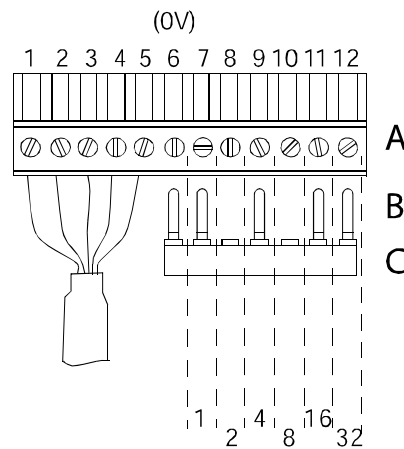

xx0100000245

A	Connector X5
B	Address pins
C	Address key



Note

Do not change the address with power on.

Connector X5

Connector X5 is a DeviceNet connector. The following table shows the connections to connector X5.

Signal name	X5 pin
1	Supply voltage GND - Black
2	CAN signal low - Blue
3	Shield
4	CAN signal high - White
5	Supply voltage 24 VDC - Red
6	Logic GND
7	Board ID bit 0 (LSB)

Continues on next page

Signal name	X5 pin
8	Board ID bit 1
9	Board ID bit 2
10	Board ID bit 3
11	Board ID bit 4
12	Board ID bit 5 (MSB)

This page is intentionally left blank

7 System parameters

7.1 Introduction

About the system parameters

There are both DeviceNet specific parameters and general I/O parameters. This chapter describes all DeviceNet specific system parameters. The parameters are divided into the type they belong to.

For information about other system parameters, see *Technical reference manual - System parameters*.

DeviceNet system parameters

DeviceNet Network

These parameters belong to the type *DeviceNet Network* in the topic *I/O System*.

Parameter	For more information, see
Name	Name on page 62
Identification Label	Identification Label on page 63
Address	Address on page 64
DeviceNet Communication Speed	DeviceNet Communication Speed on page 65
Simulated	Simulated on page 66

DeviceNet Device

These parameters belong to the type *DeviceNet Device* in the topic *I/O System*.

Parameter	For more information, see
Name	Name on page 67
Connected to Industrial Network	Connected to Industrial Network on page 68
State when System Startup	State when System Startup on page 69
Trust Level	Trust Level on page 70
Simulated	Simulated on page 71
Vendor Name	Vendor Name on page 72
Product Name	Product Name on page 73
Identification Label	Identification Label on page 74
Address	Address on page 75
Vendor ID	Vendor ID on page 76
Product Code	Product Code on page 77
Device Type	Device Type on page 78
Production Inhibit Time	Production Inhibit Time on page 79
Connection Type	Connection Type on page 80
PollRate	Poll Rate on page 81

Continues on next page

7 System parameters

7.1 Introduction

Continued

Parameter	For more information, see
Connection Output Size	Connection Output Size on page 82
Connection Input Size	Connection Input Size on page 83
Quick Connect	Quick Connect on page 84

DeviceNet Internal Device

These parameters belong to the type *DeviceNet Internal Device* in the topic *I/O System*.

Parameter	For more information, see
Name	Name on page 85
Connected to Industrial Network	Connected to Industrial Network on page 86
Vendor Name	Vendor Name on page 87
Product Name	Product Name on page 88
Identification Label	Identification Label on page 89
Connection Output Size	Connection Output Size on page 91
Connection Input Size	Connection Input Size on page 90

DeviceNet Command

These parameters belong to the type *DeviceNet Command* in the topic *I/O System*.

Parameter	For more information, see
Name	Name on page 94
Device	Device on page 95
Download Order	Download Order on page 96
Path	Path on page 98
Service	Service on page 100
Value	Value on page 97

7.2 Type DeviceNet Network

7.2.1 The DeviceNet Network type

Overview

This section describes the type *DeviceNet Network*, which belongs to the topic *I/O System*. Each parameter of the type is described in a separate information topic in this section.

Type description

The type *DeviceNet Network* is a logical representation of a DeviceNet network in the robot controller.

Usage

The network configuration defines the specific parameters that will determine the behavior for the industrial network, like communication speed, address, connection, etc. The industrial network is used when defining the I/O devices and other objects in the I/O system.

Limitations

The DeviceNet option must be installed.

Related information

Application manual - DeviceNet Master/Slave.

7 System parameters

7.2.2 Name

7.2.2 Name

Parent

Name belongs to the type *DeviceNet Network*, in the topic *I/O System*.

Description

The parameter *Name* specifies the name of the industrial network.

Usage

The name of the network is used as a reference to the specific network when configuring the I/O devices on the industrial network.

Default value

The default value is specified by the specific industrial network option.

Allowed values

A string of maximum 32 characters. The allowed value(s) is specified by the specific industrial network option.

The following names are allowed for the industrial networks:

- DeviceNet
- DeviceNet_Anybus
- PROFIBUS
- PROFIBUS_Anybus
- EtherNetIP
- EtherNetIP_Anybus
- PROFINET
- PROFINET_Anybus
- Local
- ICI

7.2.3 Identification Label

Parent

Identification Label belongs to the type *DeviceNet Network*, in the topic *I/O System*.

Description

Identification Label provides a way to identify the industrial network physically.

Usage

Using *Identification Label* is optional. It provides a label to identify the physical industrial network or hardware communication interface (connection port) that this network configuration is representing.

Default value

The default value is an empty string.

Allowed values

A string with maximum 80 characters.

7 System parameters

7.2.4 Address

7.2.4 Address

Parent

Address belongs to the type *DeviceNet Network*, in the topic *I/O System*.

Description

Address is mandatory for a DeviceNet industrial network and decides what address the DeviceNet master and the internal slave device should use to communicate with other devices on the DeviceNet network.

Usage

This address is the address that the DeviceNet master and the internal slave device uses to communicate.

Prerequisites

The option *DeviceNet Master/Slave* must be installed.

Limitations

The *Address* should not use the same address as another I/O device on the network.

Default value

The default value is 2.

Allowed values

Allowed values are the integers 0-63.

7.2.5 DeviceNet Communication Speed

Parent

DeviceNet Communication Speed belongs to the type *DeviceNet Network*, in the topic *I/O System*.

Description

DeviceNet Communication Speed is mandatory for a DeviceNet industrial network and decides what communication speed (baud rate) the DeviceNet master and the internal slave device should use to communicate with other devices on the DeviceNet network.

Usage

The baud rate is the signalling speed of the communication, and determines the maximum speed of the data transfer in serial channels. The higher the baud rate is, the faster the communication can be.

Prerequisites

The option *DeviceNet Master/Slave* must be installed.

Limitations

When using *DeviceNet Communication Speed*, all devices on the same physical network must use the same baud rate.

Default value

The default value is 500.

Allowed values

Allowed values are 125, 250, and 500, specifying the baud rate in Kbps (kilobits per second).

7 System parameters

7.2.6 Simulated

7.2.6 Simulated

Parent

Simulated belongs to the type *DeviceNet Network*, in the topic *I/O System*.

Description

The parameter *Simulated* specifies that the industrial network and all I/O devices connected to it should be treated as simulated.

Default value

The default value is No.

Allowed values

Yes

No

7.3 Type DeviceNet Device

7.3.1 Name

Parent

Name belongs to the type *DeviceNet Device*, in the topic *I/O System*.

Description

The parameter *Name* specifies the name of the industrial network.

Usage

The name of the network is used as a reference to the specific network when configuring the I/O devices on the industrial network.

Default value

The default value is specified by the specific industrial network option.

Allowed values

A string of maximum 32 characters. The allowed value(s) is specified by the specific industrial network option.

The following names are allowed for the industrial networks:

- DeviceNet
- DeviceNet_Anybus
- PROFIBUS
- PROFIBUS_Anybus
- EtherNetIP
- EtherNetIP_Anybus
- PROFINET
- PROFINET_Anybus
- Local
- ICI

7 System parameters

7.3.2 Connected to Industrial Network

7.3.2 Connected to Industrial Network

Parent

Connected to Industrial Network belongs to the type *DeviceNet Device*, in the topic *I/O System*.

Description

The parameter *Connected to Industrial Network* specifies which industrial network this I/O device is physically connected to.

Default value

The default value is an empty string.

Allowed values

A string with maximum 32 characters.

The string must follow the RAPID rules described in *Technical reference manual - RAPID Overview*.

The name must be unique among all named objects in the I/O system configuration.



Note

Names differing only in upper and lower case are considered to be equal.

7.3.3 State when System Startup

Parent

State when System Startup belongs to the type *DeviceNet Device*, in the topic *I/O System*.

Description

The parameter *State when System Startup* defines which logical state the I/O device shall have after startup of the robot system..

Usage

The parameter *State when System Startup* value defines the logical state that the robot system shall try to set for the I/O device when system startup. The available options are:

- Establish communication (*Activated*)
 - Don't establish communication (*Deactivated*)
 - Restore the previously stored logical state for the I/O device at system shutdown (*Last State*)
-

Default value

The default value is *Activated*.

Allowed values

Activated
Deactivated
Last State

7 System parameters

7.3.4 Trust Level

7.3.4 Trust Level

Parent

Trust Level belongs to the type *DeviceNet Device*, in the topic *I/O System*.

Description

The parameter *Trust Level* defines the behavior for I/O devices at different execution situations in the robot controller.

The *Trust Level* only affects physical devices controlled by an industrial network master in the robot controller. An internal slave device is not controlled by an industrial network master in the robot controller and is therefore not affected by the *Trust Level* setting.

Usage

This parameter is used to specify the I/O device behavior as per the user requirements at different error situations in the robot controller.

Default value

The default value is *DefaultTrustLevel*.

Allowed values

A string corresponding to the name of a defined *Device Trust Level* type.

A string with maximum 32 characters.

The string must follow the RAPID rules described in *Technical reference manual - RAPID Overview*.

The name must be unique among all named objects in the I/O system configuration.



Note

Names differing only in upper and lower case are considered to be equal.

7.3.5 Simulated

Parent

Simulated belongs to the type *DeviceNet Device*, in the topic *I/O System*.

Description

The parameter *Simulated* specifies that the industrial network and all I/O devices connected to it should be treated as simulated.

Default value

The default value is No.

Allowed values

Yes

No

7 System parameters

7.3.6 Vendor Name

RobotWare - OS

7.3.6 Vendor Name

Parent

Vendor Name belongs to the type *DeviceNet Device*, in the topic *I/O System*.

Description

The parameter *Vendor Name* specifies the name of the I/O device vendor.

Usage

This parameter is optional and only used as information.

Allowed values

A string with maximum 80 characters.

7.3.7 Product Name

Parent

Product Name belongs to the type *DeviceNet Device*, in the topic *I/O System*.

Description

The parameter *Product Name* specifies the product name for this I/O device according to industrial network type standard.

Usage

This parameter is optional and only used as information.

Allowed values

A string with maximum 80 characters.

7 System parameters

7.3.8 Identification Label

7.3.8 Identification Label

Parent

Identification Label belongs to the type *DeviceNet Device*, in the topic *I/O System*.

Description

Identification Label provides a way to identify the industrial network physically.

Usage

Using *Identification Label* is optional. It provides a label to identify the physical industrial network or hardware communication interface (connection port) that this network configuration is representing.

Default value

The default value is an empty string.

Allowed values

A string with maximum 80 characters.

7.3.9 Address

Parent

Address belongs to the type *Device*, in the topic *I/O System*.

Description

The parameter *Address* specifies the address of the I/O device on the network.

Usage

Address specifies the address that the I/O device uses on the network, to which the scanner should set up connection.

Prerequisites

The option *DeviceNet Master/Slave* must be installed.

Limitations

All addresses on a DeviceNet network must be unique, the only exception is that the master and the internal slave device share the same address.

Default value

The default value is 63, when option *DeviceNet Master/Slave* is installed.

Allowed values

In DeviceNet network, allowed values are the integers 0-63.

7 System parameters

7.3.10 Vendor ID

7.3.10 Vendor ID

Parent

Vendor ID belongs to the type *Device*, in the topic *I/O System*.

Description

Vendor ID is used as an identification of the I/O device to secure communication to the correct type of device.

Usage

This parameter is used as an identification of the I/O device to secure communication to the correct device.

The value of *Vendor ID* can be found in the Electronic Data Sheet (EDS) for the device (called VendCode in EDS file) in DeviceNet network, or by using a predefined device template in DeviceNet network.

Prerequisites

The option *3029-1 DeviceNet Single channel* must be installed.

Default value

The default value is 0.

Allowed values

Allowed values are the integers 0-65535.

Additional information

The I/O device vendor number is assigned by Open DeviceNet Vendor Associations (ODVA) to the vendor of the specific I/O device.

7.3.11 Product Code

Parent

Product Code belongs to the type *Device*, in the topic *I/O System*.

Description

Product Code is used as an identification of the I/O device to secure communication to the correct I/O device.

Usage

This parameter is used as an identification of the I/O device to secure communication to the correct device.

The value of *Product Code* can be found in Electronic Data Sheet (EDS) for the device (called ProdCode in EDS file) in DeviceNet network, or by using a predefined device template in DeviceNet network.

Prerequisites

The option *3029-1 DeviceNet Single channel* must be installed.

Default value

Default value is 0.

Allowed values

Allowed values are the integers 0-65535.

Additional information

The device product code is defined by the vendor of the device and shall be unique for the actual product type.

7 System parameters

7.3.12 Device Type

7.3.12 Device Type

Parent

Device Type belongs to the type *Device*, in the topic *I/O System*.

Description

The parameter *Device Type* specifies the device type of this I/O device as defined by the Open DeviceNet Vendor Association.

Usage

This parameter is used as an identification of the I/O device to secure communication to the correct device.

The value of this parameter can be found in the Electronic Data Sheet (EDS) for the device (called ProdType in EDS file) in DeviceNet network, or by using a predefined device template in DeviceNet network.

Prerequisites

The option *3029-1 DeviceNet Single channel* must be installed.

Default value

The default value is 0.

Allowed values

Allowed values are the integers 0-65535.

7.3.13 Production Inhibit Time

Parent

Production Inhibit Time belongs to the type *Device*, in the topic *I/O System*.

Description

Production Inhibit Time specifies the minimum time, expressed in milliseconds, between network messages sent by the device.

Usage

Production Inhibit Time is used to control the minimum time between transmissions from the I/O device in order to prevent overloading of the DeviceNet network. This parameter is only applicable when connection type is set to Change-Of-State (COS) connection or Change-Of-State with acknowledge suppression.

Prerequisites

The option *DeviceNet Master/Slave* must be installed.

Limitations

Maximum and minimum values might be constrained by the device. This parameter is *not* applicable when connection type is set to polled or strobe connection.

Default value

The default value is 10.

Allowed values

Allowed values are the integers 0-65535.

7 System parameters

7.3.14 Connection Type

7.3.14 Connection Type

Parent

Connection Type belongs to the type *Device*, in the topic *I/O System*.

Description

Connection Type specifies the type of the first connection that should be established to the device.

Usage

Connection Type is used to define the communication scheme used towards the I/O device. The different connection types are described in the ODVA DeviceNet specification (Open DeviceNet Vendor Associations).

The type of connection supported by the I/O device can either be found in the [IO_Info] section of the Electronic Data Sheet (EDS) for the device, or by using a predefined device template.

Prerequisites

The option *DeviceNet Master/Slave* must be installed.

Limitations

All connection types may not be supported by device.

Default value

The default value is Polled connection.

Allowed values

Allowed values are:

- Polled connection
 - Strobe connection
 - Change-Of-State (COS) connection
 - Cyclic connection
 - Change-Of-State with Acknowledge Suppression
 - Cyclic with Acknowledge Suppression
-

7.3.15 Poll Rate

Parent

Poll Rate belongs to the type *Device*, in the topic *I/O System*.

Description

Poll Rate defines the cyclicity of the communication over the first connection.

Usage

Poll Rate is used to optimize network bandwidth and I/O update rates.



Note

When using a COS connection on DeviceNet Master/Slave a DO signal will be updated directly on a device.

Prerequisites

The option *DeviceNet Master/Slave* must be installed.

Limitations

Maximum and minimum values might be constrained by the device.

Default value

The default value is 1000.

Allowed values

Allowed values are the integers 0-65535, specifying the time in milliseconds.

7 System parameters

7.3.16 Connection Output Size

7.3.16 Connection Output Size

Parent

Connection Output Size belongs to the type *Device*, in the topic *I/O System*.

Description

Connection Output Size defines the data size that is transmitted to the device over the first connection.

Usage

The value of *Connection Output Size* can either be found in the [IO_Info] section of the Electronic Data Sheet (EDS) for the device, or by using a predefined device template.

Prerequisites

The option *DeviceNet Master/Slave* must be installed.

Limitations

Maximum and minimum values might be constrained by the device.

Default value

Default value is 0.

Allowed values

Allowed values are the integers 0-64 (0-512 signal bits), specifying the data size in bytes.

For devices that can give the device size itself by an explicit message, the value -1 is also allowed.

7.3.17 Connection Input Size

Parent

Connection Input Size belongs to the type *Device*, in the topic *I/O System*.

Description

Connection Input Size defines the data size received from the device over the first connection.

Usage

The value of *Connection Input Size* can either be found in the [IO_Info] section of the Electronic Data Sheet (EDS) for the device, or by using a predefined device template.

Prerequisites

The option *DeviceNet Master/Slave* must be installed.

Limitations

Maximum and minimum values might be constrained by the device.

Default value

The default value is 0.

Allowed values

Allowed values are the integers 0-64 (0-512 signal bits), specifying the data size in bytes.

For devices that can give the device size itself by an explicit message, the value -1 is also allowed.

7 System parameters

7.3.18 Quick Connect

7.3.18 Quick Connect

Parent

Quick Connect belongs to the type *Device*, in the topic *I/O System*.

Description

The *Quick Connect* parameter enables the quick connect option on the master side of a connection to a device.

Usage

Quick Connect is used to shorten the time when an I/O device is activated from a deactivated state.

Prerequisites

The option *DeviceNet Master/Slave* must be installed.

Default value

The default value is *Deactivated*, when option *DeviceNet Master/Slave* is installed.

Allowed values

In DeviceNet network, allowed values are *Activated* or *Deactivated*.

Additional information

To be able to use this option completely, the I/O device must support Quick Connect according to the ODVA DeviceNet Specification.

7.4 Type DeviceNet Internal Device

7.4.1 Name

Parent

Name belongs to the type *DeviceNet Internal Device*, in the topic *I/O System*.

Description

The parameter *Name* specifies the name of the industrial network.

Usage

The name of the network is used as a reference to the specific network when configuring the I/O devices on the industrial network.

Default value

The default value is specified by the specific industrial network option.

Allowed values

A string of maximum 32 characters. The allowed value(s) is specified by the specific industrial network option.

The following names are allowed for the industrial networks:

- DeviceNet
- DeviceNet_Anybus
- PROFIBUS
- PROFIBUS_Anybus
- EtherNetIP
- EtherNetIP_Anybus
- PROFINET
- PROFINET_Anybus
- Local
- ICI

7 System parameters

7.4.2 Connected to Industrial Network

7.4.2 Connected to Industrial Network

Parent

Connected to Industrial Network belongs to the type *DeviceNet Internal Device*, in the topic *I/O System*.

Description

The parameter *Connected to Industrial Network* specifies which industrial network this I/O device is physically connected to.

Default value

The default value is an empty string.

Allowed values

A string with maximum 32 characters.

The string must follow the RAPID rules described in *Technical reference manual - RAPID Overview*.

The name must be unique among all named objects in the I/O system configuration.



Note

Names differing only in upper and lower case are considered to be equal.

7.4.3 Vendor Name

Parent

Vendor Name belongs to the type *DeviceNet Internal Device*, in the topic *I/O System*.

Description

The parameter *Vendor Name* specifies the name of the I/O device vendor.

Usage

This parameter is optional and only used as information.

Allowed values

A string with maximum 80 characters.

7 System parameters

7.4.4 Product Name

RobotWare - OS

7.4.4 Product Name

Parent

Product Name belongs to the type *DeviceNet Internal Device*, in the topic *I/O System*.

Description

The parameter *Product Name* specifies the product name for this I/O device according to industrial network type standard.

Usage

This parameter is optional and only used as information.

Allowed values

A string with maximum 80 characters.

7.4.5 Identification Label

Parent

Identification Label belongs to the type *DeviceNet Internal Device*, in the topic *I/O System*.

Description

Identification Label provides a way to identify the industrial network physically.

Usage

Using *Identification Label* is optional. It provides a label to identify the physical industrial network or hardware communication interface (connection port) that this network configuration is representing.

Default value

The default value is an empty string.

Allowed values

A string with maximum 80 characters.

7 System parameters

7.4.6 Connection Input Size

7.4.6 Connection Input Size

Parent

Connection Input Size belongs to the type *DeviceNet Internal Device*, in the topic *I/O System*.

Description

Connection Input Size defines the data size in bytes for the input area received from the connected DeviceNet master.

Usage

Connection Input Size is a DeviceNet specific parameter.

Prerequisites

The option *DeviceNet Master/Slave* must be installed.

Default value

The default value is 8.

Allowed values

Allowed values are the integers 0-64, specifying the data size in bytes.

7.4.7 Connection Output Size

Parent

Connection Output Size belongs to the type *DeviceNet Internal Device*, in the topic *I/O System*.

Description

Connection Output Size defines the data size in bytes for the output area sent to the DeviceNet master.

Usage

Connection Output Size is a DeviceNet specific parameter.

Prerequisites

The option *DeviceNet Master/Slave* must be installed.

Default value

Default value is 8.

Allowed values

Allowed values are the integers 0-64, specifying the data size in bytes.

7 System parameters

7.4.8 Connection Type

7.4.8 Connection Type

Parent

Connection Type belongs to the type *DeviceNet Internal Device*, in the topic *I/O System*.

Description

Connection Type specifies the type of the first connection that should be established to the device.

Usage

Connection Type is used to define the communication scheme used towards the I/O device. The different connection types are described in the ODVA DeviceNet specification (Open DeviceNet Vendor Associations).

The type of connection supported by the I/O device can either be found in the [IO_Info] section of the Electronic Data Sheet (EDS) for the device, or by using a predefined device template.

Prerequisites

The option *DeviceNet Master/Slave* must be installed.

Limitations

All connection types may not be supported by device.

Default value

The default value is Polled connection.

Allowed values

Allowed values are:

- Polled connection
 - Change-Of-State (COS) connection
-

7.4.9 Poll Rate

Parent

Poll Rate belongs to the type *DeviceNet Internal Device*, in the topic *I/O System*.

Description

Poll Rate defines the cyclicity of the communication over the first connection.

Usage

Poll Rate is used to optimize network bandwidth and I/O update rates.

**Note**

When using a polled connection on *DeviceNet Master/Slave* a DO signal will be updated directly on a device.

Prerequisites

The option *DeviceNet Master/Slave* must be installed.

Limitations

Maximum and minimum values might be constrained by the device.

Default value

The default value is 1000.

Allowed values

Allowed values are the integers 0-65535, specifying the time in milliseconds.

7 System parameters

7.5.1 Name

7.5 Type DeviceNet Command

7.5.1 Name

Parent

Name belongs to the type *DeviceNet Command*, in the topic *I/O System*.

Description

The parameter *Name* specifies the name of the industrial network.

Usage

The name of the network is used as a reference to the specific network when configuring the I/O devices on the industrial network.

Default value

The default value is specified by the specific industrial network option.

Allowed values

A string of maximum 32 characters. The allowed value(s) is specified by the specific industrial network option.

The following names are allowed for the industrial networks:

- DeviceNet
- DeviceNet_Anybus
- PROFIBUS
- PROFIBUS_Anybus
- EtherNetIP
- EtherNetIP_Anybus
- PROFINET
- PROFINET_Anybus
- Local
- ICI

7.5.2 Device

Parent

Device belongs to the type *DeviceNet Command*, in the topic *I/O System*.

Description

Specifies the name of the I/O device the command is connected to.

Default value

The default value is an empty string.

Allowed values

A string defining the name of the I/O device with maximum 32 characters.

**Note**

Names that differ only in upper and lower case are considered to be equal.

Related information

[Type DeviceNet Device on page 67.](#)

7 System parameters

7.5.3 Download Order

7.5.3 Download Order

Parent

Download Order belongs to the type *DeviceNet Command*, in the topic *I/O System*.

Description

The parameter *Download Order* specifies the sequence number in which this command shall be downloaded to the I/O device that have several commands assigned to it.

Usage

Use *Download Order* to control the order in which the commands are downloaded (and executed) on an I/O device.

Lower download orders are downloaded before higher download orders.

Default value

The default value is 0.

Allowed values

0 - 100.

7.5.4 Value

Parent

Value belongs to the type *DeviceNet Command*, in the topic *I/O System*.

Description

The parameter *Value* specifies the value for this command.

Default value

The default value is an empty string.

Allowed values

A string with maximum 200 characters.

7 System parameters

7.5.5 Path

7.5.5 Path

Parent

Path belongs to the type *DeviceNet Command*, in the topic *I/O System*.

Description

Path defines the path to DeviceNet object instance or attribute. Information about how to define this can usually be found in the [param] section of the EDS file.

Usage

Path is used to describe the path to the instance or attribute, the data type identifier and the data size that are to be affected by the explicit message.

Prerequisites

The option *DeviceNet Master/Slave* must be installed.

Default value

The default value is an empty string.

Allowed values

A string with maximum 30 characters.

Continues on next page

Related information

ODVA DeviceNet Specification 2.0.

Example

6,20 01 24 08 30 01,C6,1

Description of example:

- 6 is the length of the path - that is, the number of hexadecimal figures until the next comma.
- Path (20 01 24 08 30 01) is a software description of DeviceNet class, instance and attribute. A further description can be found in the ODVA DeviceNet Specification 2.0.
- C6 is the hexadecimal value for the data type identifier.
- 1 is the data size - that is, the number of bytes as a hexadecimal value.

7 System parameters

7.5.6 Service

7.5.6 Service

Parent

Service belongs to the type *DeviceNet Command*, in the topic *I/O System*.

Description

Service defines the explicit service that should be performed on DeviceNet object instance or attribute pointed out in *Path*.

Usage

Service is used to define the type of action to be used.

Prerequisites

The option *DeviceNet Master/Slave* must be installed.

Default value

The default value is *Set_Attribute_Single*.

Allowed values

Following values are allowed:

- *Reset*
 - *Create*
 - *Apply_Attributes*
 - *Set_Attribute_Single*
-

Related information

[Path on page 98.](#)

8 Troubleshooting

8.1 Bus off

Description

The master/slave channel goes bus off when an excessive number of communication errors are detected and the CAN chip automatically goes off-line. An event message will inform the users that bus off has occurred. The master/slave channel will automatically try to recover from bus off and if succeeded an event message will inform the user that the master/slave channel has recovered from bus off.

The network can be restarted from FlexPendant or RobotStudio. When the DeviceNet network is in error state, tap the Start button under *Industrial Network* in FlexPendant.

Consequences

Bus off indicates a serious communication fault such as incorrect baud rate or physical layer error (short, open etc.).

Possible causes

The symptom is caused by:

- Different baud rates on the master and some I/O devices (the I/O devices do not support auto baud rate).
- No power or faulty power on the network.
- Short circuit between CAN high and CAN low.
- Cable length on trunk cables and drop cables.
- Faulty terminations.

Recommended actions

In order to remedy the symptom, the following actions are recommended:

Cause	Action/Info
Different baud rates on the master and some devices. (The I/O devices do not support auto baud rate.)	Cycle the power of the devices or manually change the baud rate of the devices.
No power or faulty power on the network.	Refer to Shield grounding and power on page 22
Cable length on trunk cables and drop cables.	Refer to Selecting cables on page 26 or Repeaters on page 27 .
Faulty terminations.	Refer to Termination resistors on page 24 .



Note

If the master/slave channel goes bus off, the devices on the network also can go bus off. The only way to recover these devices is to cycle the power on the device (the behavior may be different depending on the manufacturer of the device).

8 Troubleshooting

8.2 Bus Scan

8.2 Bus Scan

Overview

When a bus scan or automatic configuration operation is activated, the DeviceNet master will send requests to all valid network addresses. If the device is already configured against another DeviceNet master, or operating at wrong baud rate, or is not online, the device can not be contacted for the data gathering of the required configuration parameters. If the device is not found with automatic configuration, it might still be possible that the device will work if it is manually added.

Index

B

- bus off, 101
 - causes, 101
 - consequences, 101
 - remedy, 101

C

- cable length, 26
- coil neutralization, 55
- connector X5, 56

D

- DeviceNet, 15
 - connector, 56
 - master, 42
 - network, 24
 - network ID, 56
 - predefined network, 33
 - specification overview, 17
- DeviceNet cable, 26
 - incoming, 25
 - outgoing, 25
- DeviceNet generic device template, 33, 47
- DeviceNet master
 - configuration, 42, 49
- Device Template, 33
- drop line, 25
 - extending the length, 28

E

- explicit messages, 15

I

- I/O devices, 29
- I/O messages, 15
 - change-of-state connection, 16
 - change-of-state with acknowledge suppression, 16
 - cyclic connection, 16
 - cyclic with acknowledge suppression, 16
 - polled connection, 15
 - strobe connection, 15
- integrator responsibility, 11
- internal DeviceNet slave
 - configuration, 49
 - I/O connection, 32
 - limitations, 32
- internal slave device
 - predefined internal slave device, 31
- Internal slave device, 13

L

- LED, 51
 - common LEDs, 51
 - DeviceNet Rx, 52
 - DeviceNet Tx, 52
 - module status, 51
 - network status, 52
 - specific LEDs, 51
 - test run, 53
- Limitation
 - I/O devices, 34

N

- network security, 12

P

- predefined device template, 47
- predefined network, 31, 33

R

- repeaters, 27

S

- safety, 11
- shield grounding, 22
- system integrator requirements, 11
- system parameters
 - Connection Input Size, 83
 - Connection Output Size, 82
 - Connection Type, 59, 80, 92
 - DeviceNet Address, 64, 75
 - DeviceNet Communication Speed, 65
 - Device Type, 78
 - Path, 98
 - Poll Rate, 81, 93
 - Product Code, 77
 - Production Inhibit Time, 79
 - Quick Connect, 84
 - Service, 100
 - Vendor ID, 76

T

- T-connector, 25
- template I/O configuration file, 34
- termination resistor, 24, 27
- topic I/O System, 31
 - Device, 59
 - DeviceNet Command, 60
 - device template, 33
 - Industrial Network, 31, 59
- troubleshooting, bus off, 101
- trunk line, 25
 - extending the length, 27



ABB AB

Robotics & Discrete Automation

S-721 68 VÄSTERÅS, Sweden

Telephone +46 10-732 50 00

ABB AS

Robotics & Discrete Automation

Nordlysvegen 7, N-4340 BRYNE, Norway

Box 265, N-4349 BRYNE, Norway

Telephone: +47 22 87 2000

ABB Engineering (Shanghai) Ltd.

Robotics & Discrete Automation

No. 4528 Kangxin Highway

PuDong New District

SHANGHAI 201319, China

Telephone: +86 21 6105 6666

ABB Inc.

Robotics & Discrete Automation

1250 Brown Road

Auburn Hills, MI 48326

USA

Telephone: +1 248 391 9000

abb.com/robotics